

# CS 578 – Software Architectures

## Fall 2009

### Homework Assignment #1

**Due:** *Tuesday, October 20, 2009*

In this assignment, you are required to provide an architectural description of a subset of the C4 system. You are to use the C2SADEL architecture description language (ADL), which is described in this assignment's addendum, and which was overviewed in class.<sup>1</sup> Your architectural description should reflect the architectural breakdown given in the figure below. The architecture adheres to the C2 style. You should include full specifications of all component and connector types, as well as their instantiations and interconnections in the depicted configuration.

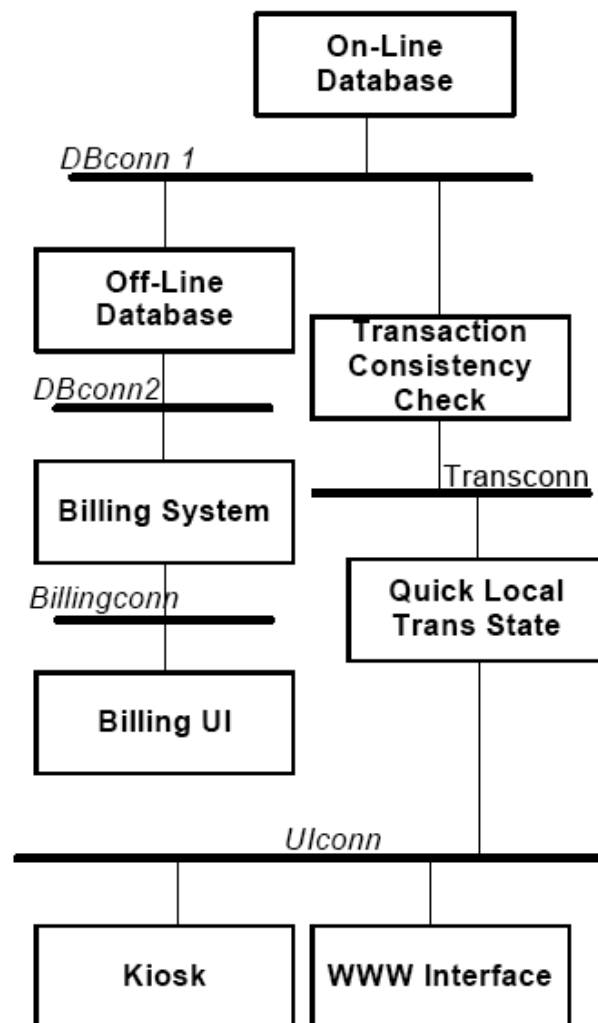

---

<sup>1</sup> You can find detailed information on C2SADEL at <http://sunset.usc.edu/~nenodissertation/dissertation2.pdf>.

The architecture must meet at least the following C4 system requirements:

1. Checking for conflicting tasks. The possible conflicts will be based on the information included in the Databases (see below).
2. Automatic daily updating of the Off-Line Database.
3. Support for long-lasting, interrupted sessions. You may make use of specialized operations and/or fields in the database. Additionally, incorporate a mechanism for generating reminders to assist the customer representatives (e.g., a popup at a time requested by the customer). Involved components will probably be Kiosk and WWW Interface, Local Transaction State, and the On- Line Database.
4. Billing inquiries and billing calculations and printing.
5. Customer access through WWW or Kiosks.

You may assume that the On-Line Database will include the following information:

1. Name
2. Date of birth
3. SSN
4. Address
5. Phone number(s)
6. Voice mail
7. Caller ID
8. Three-way calling
9. Numbers called or services accessed (e.g. Directory service)
10. Long distance provider
11. Numbers called and duration during the past three months

The Off-Line Database will include the following information:

1. Phone number
2. Numbers called and duration during the past three months
3. Rates
4. Amounts charged per phone call

## ADDENDUM: An Overview of C2SADEL

This addendum introduces C2SADEL, a *Software Architecture Description and Evolution Language* for C2-style architectures. The complete specification of C2SADEL's syntax is given below. C2SADEL supports component evolution via heterogeneous subtyping and facilitates architectural descriptions that allow establishment of type-theoretic notions of architectural soundness. It also supports modeling of connectors with context-reflective interfaces and different data filtering capabilities, as well as configurations that adhere to the topological rules of the C2 style.

We encountered a tension between formality and practicality in designing C2SADEL. Our goal was a language that was simple enough to be usable in practice, yet formal enough to adequately support analysis and evolution. For this reason, we kept the syntax simple and reduced formalism to a minimum.

A C2SADEL specification consists of either a set of component types or of an architecture. An architecture contains a specification of component types, connector types, and topology. To properly specify an architecture's topology, component and connector types are instantiated and connected.

### Component Types

A component specification is a type that can be defined in-line or externally (using the keyword *extern*). The specification of an external component type is given in a file different from the file in which the rest of the architecture is specified. For example,

```
component WellADT is extern {WellADT.c2;}
```

specifies that the *WellADT* component used in the KLAX architecture (Figure 1) is specified in the file *WellADT.c2*. This feature allows for components to be treated as reusable design elements, independent of an architecture. A component type consists of the following:

- state variables,
- component invariant,
- interface,
- behavior, and
- the map from interface elements to the operations of the behavior. This map is a surjective function.

A component type may be a *subtype* of another type. The exact subtyping relationship must be specified. Keywords *nam*, *int*, *beh*, and *imp* are used to denote name, interface, behavior, and implementation conformance, respectively. Different combinations of these relationships are specified using the keywords *and* and *not*. For example,

```
component WellADT is subtype Matrix (beh)
```

specifies that the KLAX component *WellADT* preserves (and possibly extends) the behavior of a component *Matrix*, but may change its interface. This relationship can be made stricter by specifying that *WellADT must alter Matrix's* interface as follows:

```
component WellADT is subtype Matrix (beh \and \not int)
```

As in a programming language, variables are specified as <name, type> pairs, as in

```
capacity : Integer;
```

Additionally, a component's state variable may also be specified as a function:

```
well_at : Integer -> Color;
```

The *well\_at* function maps a set of *Integer* locations in the well to a set of *Color* tiles at each location.

Variable types in C2SADEL, such as *Integer* or *Color*, are *basic* types and are distinguished from components, which are *architectural* types. We do not explicitly model the semantics of basic types; however, C2SADEL does allow the architect to specify that one basic type is a subtype of another:

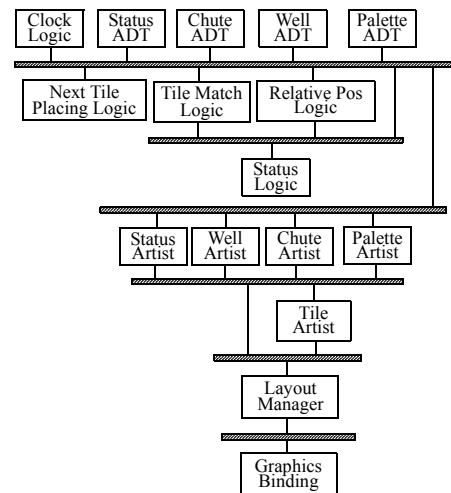

Figure 1. KLAX architecture.

```
Natural is basic_subtype Integer;
```

A component’s invariant is a conjunction of predicates specified in first-order logic. The invariant defines a set of conditions that must be satisfied throughout the component’s execution. It is specified with component state variables as operands and logical operators (`\and`, `\or`, `\not`, `\implies`, and `\equivalent`), comparison operators (`\greater`, `\less`, `\eqgreater`, `\eqless`, `=`, and `<>`), set operators (`\union`, `\intersection`, `\in`, `\not_in`, and `#`), and arithmetic operators (`+`, `-`, `*`, `/`, and `^`).<sup>1</sup> Operator precedence in C2SADEL is defined as shown in Table 1.

For example, the invariant for the *WellADT* component can be specified as follows.

```
invariant {
  (num_tiles \eqgreater 0) \and (num_tiles \eqless capacity);
}
```

A component’s interface consists of a set of interface elements. An interface element is declared with a direction indicator (*prov* or *req*), name, set of parameters, and possibly a result type. The parameter specification syntax is identical to that used in variable specification. Since interface elements may have identical names, a unique label may be assigned to each as a notational convenience. For example, in

```
prov gt1: GetTile (location : Integer) : Color;
prov gt2: GetTile (i : Natural) : GSColor;
```

both interface elements are intended to be used with operations that remove and return a tile at the given location in the KLAX *well*. The first interface element accesses a color tile at the *Integer* location *location*; the second accesses a gray-scale tile at the *Natural* location *i*. The labels, *gt1* and *gt2*, uniquely identify the two.

A component’s behavior consists of a set of operations. Each operation is declared as either *provided* or *required* and with a unique label, used to refer to the operation. Additionally, each operation may define a set of preconditions that must be true *prior* to the operation’s execution, and a set of postconditions that must be true *after* its execution. Since operations are separated from the interface elements through which they are accessed, operations also define local variables, which, along with component state variables, are used in specifying the pre- and postcondition predicates. The pre- and postconditions are specified in the same manner as component invariants. An operation’s postcondition may contain the keyword `\result`, to denote the operation’s return value. Additionally, a postcondition may specify the value of a variable after the operation has executed, denoted with a `~`, followed by the variable name.

An example operation can be specified as follows.

```
prov tileget: {
  let pos : Integer;
  pre (pos \greater 0) \and (pos \eqless num_tiles);
  post \result = well_at(pos) \and ~num_tiles = num_tiles - 1;
}
```

The local variable *pos* denotes the position in the well. *num\_tiles* and *well\_at* are component state variables. Recall that *well\_at* is a function that returns the color value of the well at the given position. The postcondition specifies that the number of tiles in the well decreases after the tile is removed.

The *tileget* operation can export multiple interfaces. For example, both *GetTile* interface elements can be mapped to the operation, provided that *GSColor* is a basic subtype of *Color*:

```
map {
  gt1 -> tileget (location -> pos);
  gt2 -> tileget (i -> pos);
}
```

**Table 1: C2SADEL operator precedence (in descending order)**

<code>#, \not</code>
<code>^</code>
<code>*, /</code>
<code>+, -</code>
<code>\union, \intersection</code>
<code>\greater, \eqgreater, \less, \eqless, =, &lt;&gt;, \in, \not_in</code>
<code>\and, \or</code>
<code>\implies, \equivalent</code>

1. `<>` denotes inequality; `\in` and `\not_in` denote set membership; `#` denotes set cardinality; `^` denotes exponentiation.

These elements are composed into a complete component specification as follows:<sup>1</sup>

```

component WellADT is subtype Matrix (beh) {
  state {
    capacity : Integer;
    num_tiles : Integer;
    well_at : Integer -> GSColor;
  }
  invariant {
    (num_tiles \eqgreater 0) \and (num_tiles \eqless capacity);
  }
  interface {
    prov gt1: GetTile (location : Integer) : Color;
    prov gt2: GetTile (i : Natural) : GSColor;
  }
  operations {
    prov tileget: {
      let pos : Integer;
      pre (pos \greater 0) \and (pos \eqless num_tiles);
      post \result = well_at(pos) \and ~num_tiles = num_tiles - 1;
    }
  }
  map {
    gt1 -> tileget (location -> pos);
    gt2 -> tileget (i -> pos);
  }
}

```

Finally, a component type may be specified as a *virtual* type: it can be used in the definition of the topology, but it does not have a specification and does not affect type checking of the architecture; furthermore, a virtual type cannot be evolved via subtyping. The concept of virtual types is useful in the case of components for which implementations are known to already exist, but which are not specified in C2SADEL.

### Connector Types

Since the connectors in this dissertation do not export a particular interface, but are context-reflective, the only aspect of connector types modeled in C2SADEL is their filtering mechanism, denoted with the *message\_filter* keyword. The different filtering mechanisms are *no\_filtering*, *notification\_filtering*, *message\_filtering*, *prioritized*, or *message\_sink*. An example broadcast connector is specified as follows.

```

connector BroadcastConn is {
  message_filter no_filtering;
}

```

### Topology

To model the topology of an architecture, component and connector types are instantiated and interconnected. Each type may be instantiated multiple times. C2SADEL requires that a component be attached to at most one connector on its top and one on its bottom; it allows multiple components and connectors to be attached to the top and bottom sides of a connector. The part of the KLAX topology that concerns the well is specified as follows.

```

architectural_topology {
  component_instances {
    Well : WellADT;
    WellArt : WellArtist;
    MatchLogic : TileMatchLogic;
  }
  connector_instances {
    ADTConn : BroadcastConn;
    ArtConn : BroadcastConn;
  }
  connections {
    connector ADTConn {
      top Well;
      bottom MatchLogic, ArtConn;
    }
    connector ArtConn {
      top ADTConn;
      bottom WellArt;
    }
  }
}

```

---

1. For illustration, the specification of *WellADT* only includes the aspects of this component previously discussed.

## C2SADEL Syntax Summary

This section contains the complete BNF specification of C2SADEL. For simplicity, all literals, including single-character literals (e.g., ‘}’ or ‘;’) are displayed in bold type. Single-character literals are displayed without quotation marks. Unless bolded, curly braces (‘{’ and ‘}’) represent repetition of the enclosed expression. “{...}\*” represents zero or more occurrences, while “{...}+” denotes one or more occurrences.

```
arch_component_set ::=
    (arch_component_type)*
arch_component_type ::=
    component identifier is arch_component_type_decl
arch_component_type_decl ::=
    component_type_decl | virtual_comp_type
arch_component_types ::=
    component_types { arch_component_set }
arch_connector_type ::=
    connector identifier is
    {
        message_filter filtering_policy ;
    }
arch_connector_types ::=
    connector_types { (arch_connector_type)* }
arch_topology ::=
    architectural_topology
    {
        component_inst
        connector_inst
        attachments
    }
attachments ::=
    connections { (connection_decl)* }
basic_subtype ::=
    identifier is basic_subtype identifier ;
basic_subtype_decl ::=
    basic_types { (basic_subtype)* }
behavior_decl ::=
    operations { (operation_decl)* }
binary_operator ::=
    = | < | > | + | - | * | / | ^ | \implies | \equivalent | \and | \or |
    \union | \intersection | \in | \not_in | \greater | \less | \eqgreater | \eqless
C2_architecture ::=
    architecture identifier is
    {
        [basic_subtype_decl]
        arch_component_types
        arch_connector_types
        arch_topology
    }
C2_component_set ::=
    [basic_subtype_decl]
    (component_type)+
C2_SADEL_spec ::=
    C2_architecture | C2_component_set
component_inst ::=
    component_instances { (instance_decl)* }
component_type ::=
    component identifier is component_type_decl
component_type_decl ::=
    extern_comp_type | local_comp_type
```

```

connection_decl ::=
  [ component | connector ] identifier
  {
    top [ connection_list ] ;
    bottom [ connection_list ] ;
  }

connection_list ::=
  identifier , connection_list | identifier

connector_inst ::=
  connector_instances { (instance_decl)* }

digit ::=
  0 | 1 | ... | 9

dir_indicator ::=
  prov | req

extern_comp_type ::=
  extern { filename ; }

filtering_policy ::=
  no_filtering | notification_filtering | message_filtering
  prioritized | message_sink

function_decl ::=
  identifier : identifier -> identifier ;

identifier ::=
  letter { _ | letter | digit } *

instance_decl ::=
  identifier : identifier ;

integer ::=
  (digit)+

interface_decl ::=
  interface { (interface_element_decl)* }

interface_element_decl ::=
  dir_indicator identifier :
  identifier ( param_decl ) [ : [ set ] identifier ] ;

invariant_decl ::=
  invariant { [logic_expr ;] }

let_decl ::=
  let { var_decl ; } * [pre_decl | post_decl]

letter ::=
  A | B | ... | Z | a | b | ... | z

local_comp_type ::=
  [subtype_decl]
  {
    state_decl
    invariant_decl
    interface_decl
    behavior_decl
    map_decl
  }

logic_expr ::=
  subexpr [ and subexpr ]

map_decl ::=
  map { (single_map)* }

numeric_literal ::=
  [-] integer [ . integer ] [ ^ integer ]

operand ::=
  [ not | # ] identifier | numeric_literal | subexpr | ( subexpr )

operation_decl ::=
  dir_indicator identifier :
  { let_decl | pre_decl | post_decl }

```

```

param_decl ::=
    var_decl ; param_decl | var_decl
param_to_var ::=
    identifier -> identifier , param_to_var |
    identifier -> identifier
post_decl ::=
    post [post_logic_expr] ;
post_logic_expr ::=
    post_subexpr [and post_subexpr]
post_operand ::=
    [not | #] [~] identifier | numeric_literal | post_subexpr | ( post_subexpr )
post_subexpr ::=
    post_operand binary_operator post_operand | result = post_operand
pre_decl ::=
    pre [logic_expr] ; [post_decl]
single_map ::=
    identifier -> identifier ( param_to_var ) ;
state_decl ::=
    state { (var_decl ; | function_decl ;)* }
subexpr ::=
    operand binary_operator operand
subtype_decl ::=
    subtype identifier ( subtype_rel_expr )
subtype_rel ::=
    nam | int | beh | imp
subtype_rel_expr ::=
    [not] subtype_rel {and [not] subtype_rel}*
var_decl ::=
    identifier : [set] identifier
virtual_comp_type ::=
    virtual { }

```