

Quantitative Architectural Modeling and Analysis Using AADL

Alex Lam, Myron Hecht, and Chris Vogl

ACE Workshop
2010 Ground Systems Architecture Workshop
March 2010

Motivation

- Need: Support to make better decisions on system architectures
- Target systems: Space vehicle and other constrained computing environments
- Development phase: Architectural decisions made during the early design impact
- Decisions supported:
 - *Extent and type of redundancy*
 - *Tradeoffs of reliability vs. Weight, power, and functional capability*
 - *Failure rate and recovery time requirements*
 - *Strategies for recovering from control and payload computing disruptions*
 - *Handling failure propagation and common mode failures*



Modeling an Embedded System Architecture

Elements of an embedded system architecture

- *Application SW Architecture (task & communication)*
- *Computer platform architecture (processors & networks)*
- *Physical system/environment (interface with embedded SW/HW)*
- *Logical interface between software and physical system*
- *Physical interface between computer platform and physical system*
- *Deployment of software on computer platform*



Introducing the Architecture Analysis & Design Language (AADL)

- Society of Automotive Engineers (SAE) Aerospace Standard AS5506 (2004)
 - *Preceded by more than a decade of development under the DARPA Meta-H program*
- Includes representations of software, computational hardware, and system components for
 - *specifying and analyzing real-time embedded systems,*
 - *mapping of software onto computational hardware elements.*
- Effective for model-based analysis and specification
 - *Evolved from DARPA Meta H project*
 - *Highly structured, defined semantics allows for modeling and analysis*
- Annex libraries define extensions to the core language concepts and syntax
 - *Behavioral Annex, ARINC 653 Annex,*
 - *Error Annex of particular interest*



AADL Components (graphical representation)

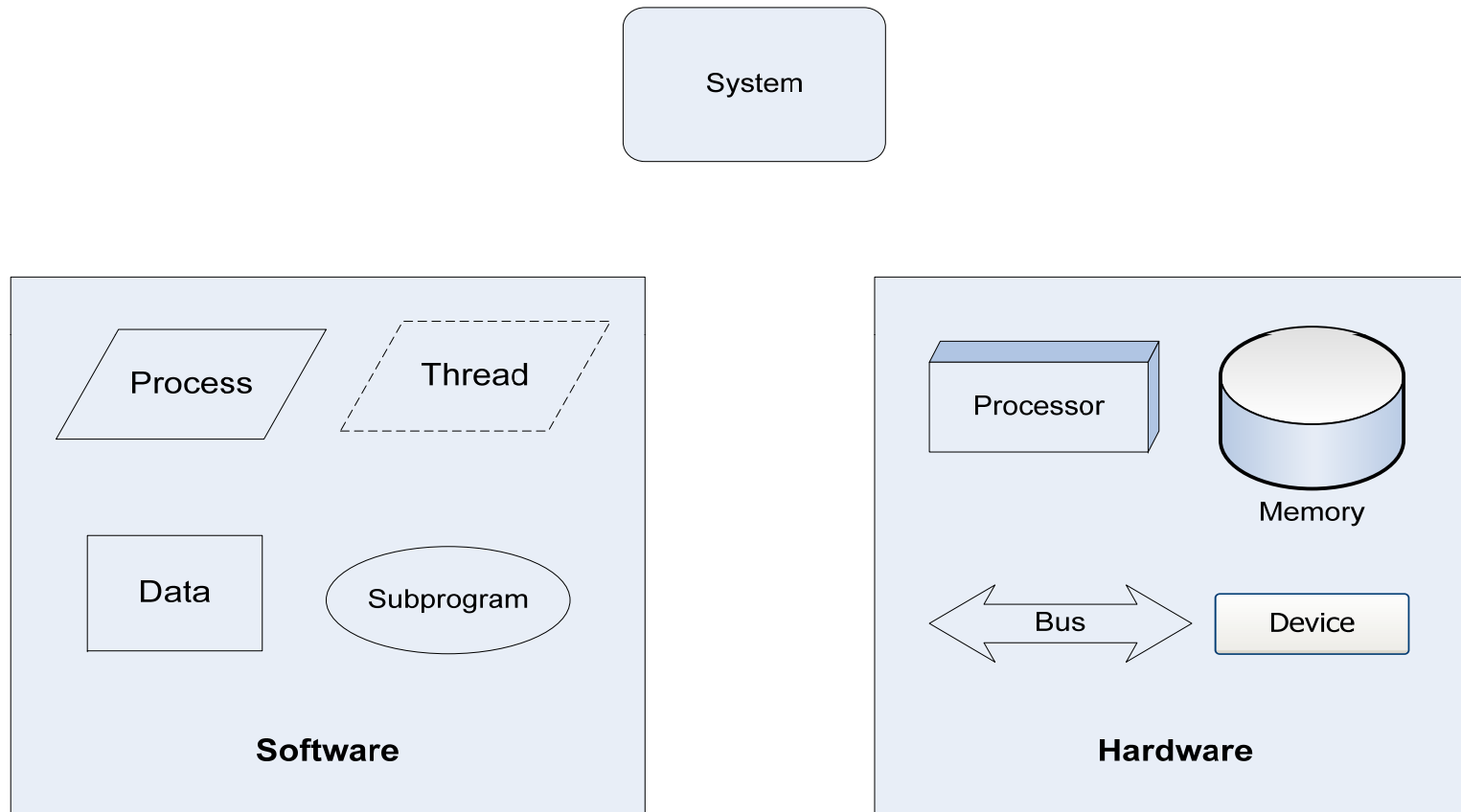

– text and xml representations also defined



AADL/UML/SysML Relationship

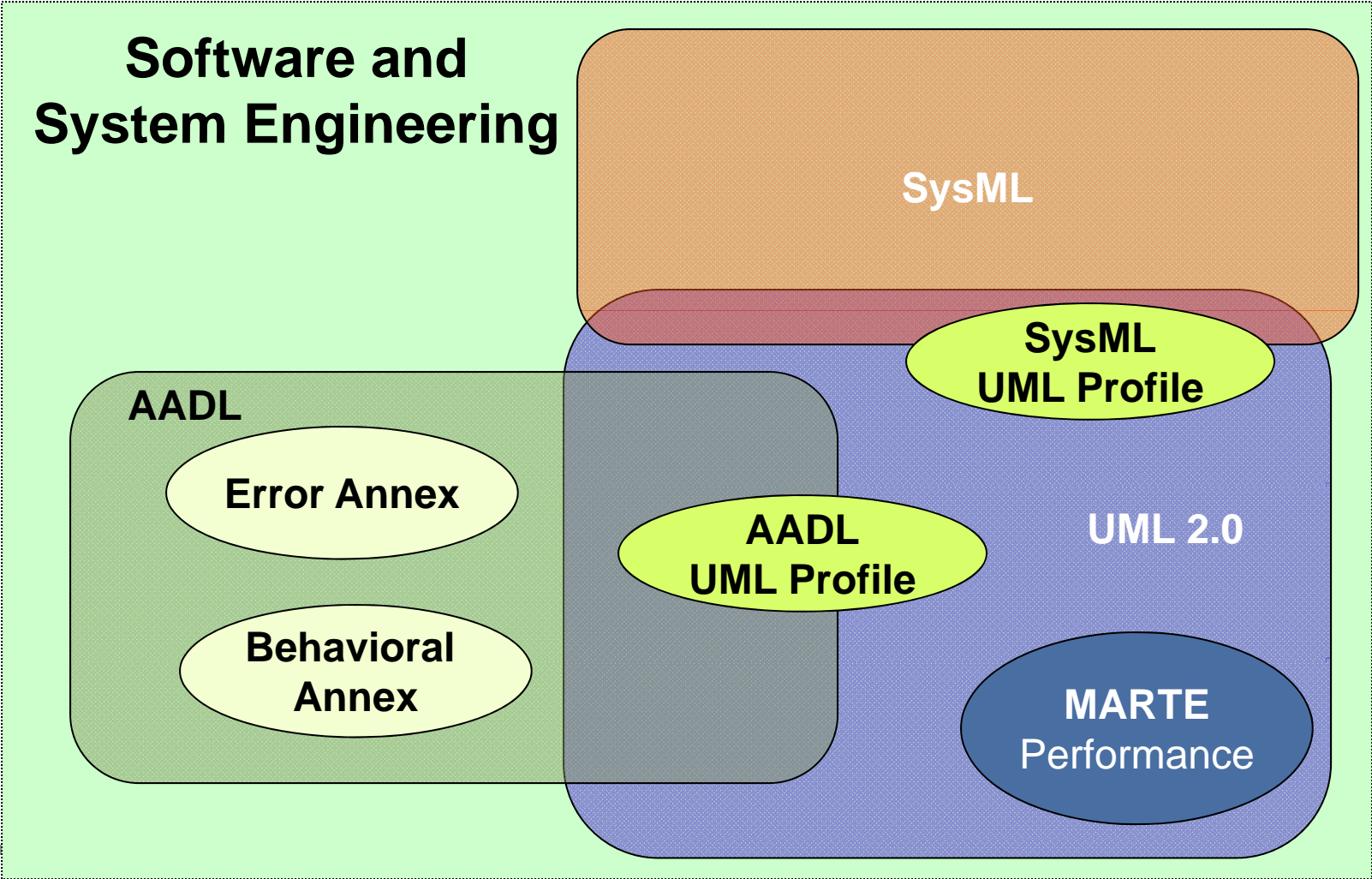

AADL Hardware/Software Architecture Representation

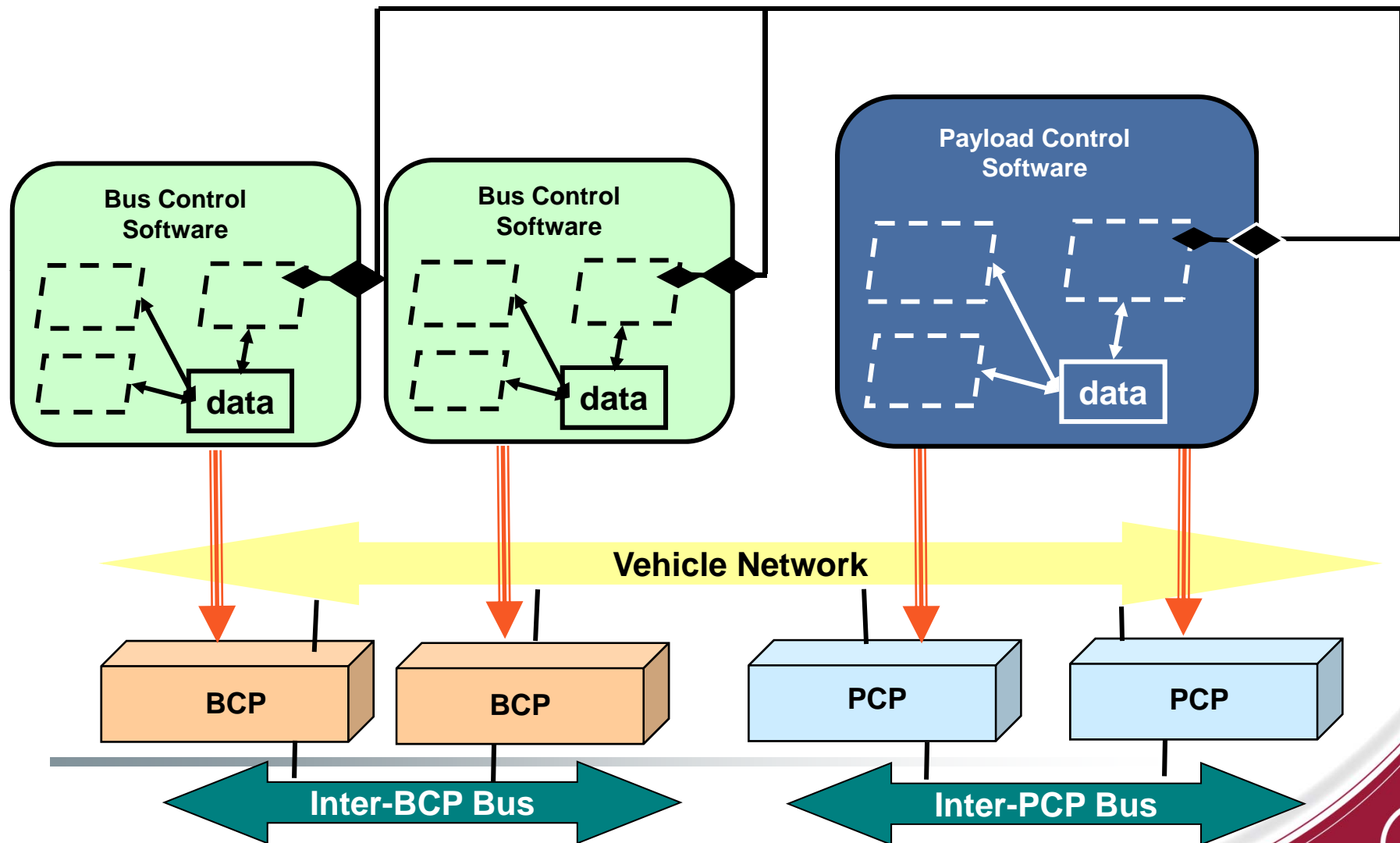

AADL Representation (using TOPCASED, continued)

BCU Diagram

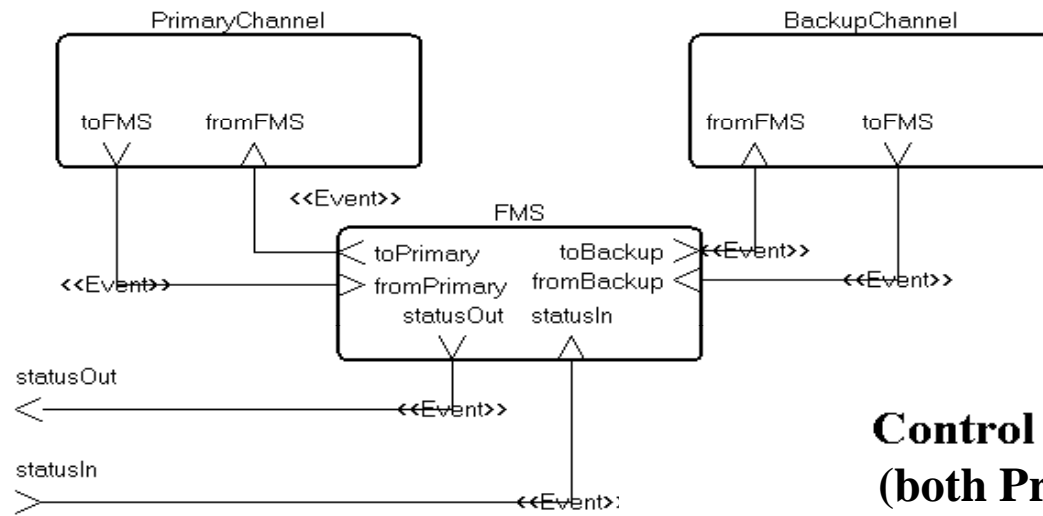

Control Channel Diagram (both Primary and Backup)

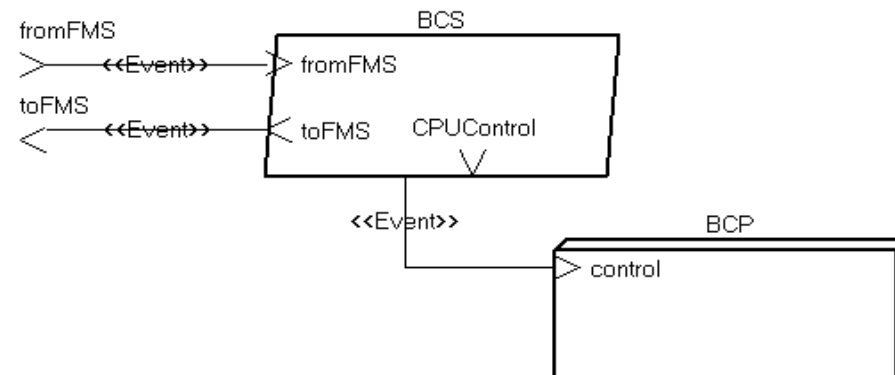

AADL Representation (using TOPCASED, continued)

Space Vehicle Diagram

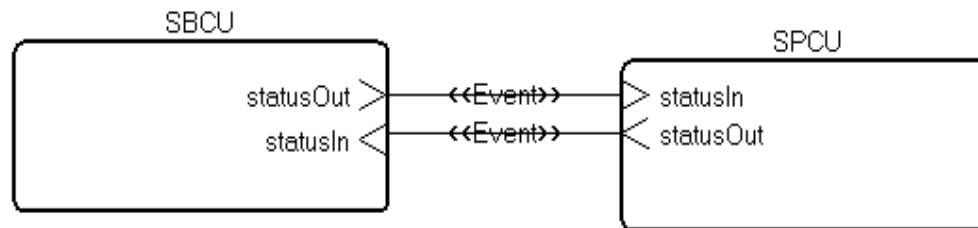

SPCU Diagram (next hierarchical level)

