



Van S. Husson – HTSI/DataLynx
 March 28, 2007

Expanding Interoperability between the AFSCN and Commercial Networks

Honeywell

Outline

- **Background**
- **DataLynx Overview**
- **APL Overview**
- **DataLynx/APL Project Task & Objectives**
- **DataLynx/APL/CERES Connectivity**

Background

1. In 2003, Congress funded and directed AFSCN to assess the feasibility of commercial augmentation
2. Civil Research Space Service (CRSS) was formed
3. The CRSS team collaborated with ongoing AFSCN Interoperability Project (IOP) to implement interoperability with civil (NASA, NOAA) and commercial networks¹
4. For the CRSS demonstration, interfaces developed under the IOP project were implemented at Commercial Remote Tracking Stations (RTSs)²
 - Universal Space Network (2003)
 - *Honeywell DataLynx partner site at the John Hopkins University Applied Physics Laboratory (2005)*
- CRSS Phase 3 Test Report were submitted in December 2006

Reference 1 GSAW briefing of Ledlow, Spindler, and Williams

Reference 2 GSAW briefing by Pietras

DataLynx Network

- Provides a single point of interface for a globally distributed network
- Provides full range of TT&C services for:
 - Launch and early orbit
 - Routine mission operations
 - Contingency operations
- Part of the **NASA Ground Network**
 - First to receive NASA Security Certification
 - 35 to 40 passes a day with Polar network
- Proven interoperability with
 - AFSCN, NASA, NOAA, USGS
 - ESA, CSA, CNES, JAXA, and DLR
- Conducts ground network architectural trade studies

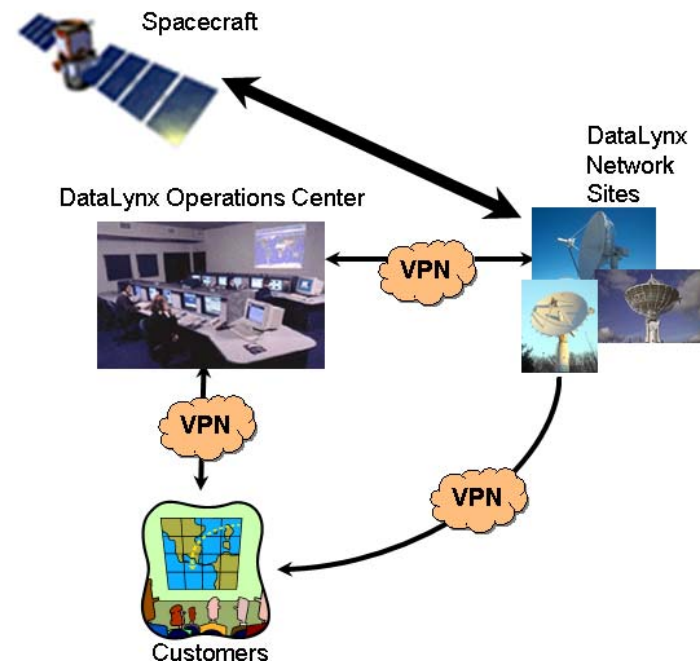

APL RTS Overview

RTS	Location	G/T	EIRP	Diameter
APL	Laurel, MD	18.3 dB/K	103 dBm	10 m

The low G/T of the APL 10 meter antenna is due to its antiquated feed design. This low G/T contributed to its inability to close the link on DSCS II.

DataLynx/APL Test Plan

- The following Test and Check-Out (TACO) Satellites were planned for availability for the demonstration

TACO	Orbit	Uplink	Downlink 1	Downlink 2	Measurands
TSX-5	LEO	2 ksps	32 kbps	1.024 Mbps	WWV
DSCS III	GEO	1 ksps	1 kbps	N/A	Illegal commanding
DSCS II	GEO	1 ksps	250 bps	N/A	N/A

- These vehicles are not representative of the most modern AFSCN missions; however, the commanding rates are still in common use
- Total Passes: 200, 100 LEO and 100 GEO
- Test Objectives:
 - Measure AFSCN Telemetry and Command Performance
 - while varying SLE parameters (command configuration modes, transfer buffer sizes, command forwarding delays, telemetry release delays)
 - Verify performance of the draft TCP/IP specifications
 - Test interface and concept of operations (CONOPS) for scheduling

DataLynx/APL CONOPS and Scheduling

- Test Satellite Operations Center (SOC) at CERES will send schedule requests to teammates at the Satellite Control Network Center (SCNC)
- SCNC will act as the Network Operations Center (NOC) for access to the DataLynx Network
- DataLynx will coordinate schedule requests between APL and SCNC
- The GST SLE Scheduling Service Management software will be used as the interface between the NOC and DataLynx
- APL will provide a secure web based interface

CRSS DataLynx/APL Project Tasks

- **Establish Communication Network**
 - DataLynx to APL
 - CERES to DataLynx
- **Scheduling**
 - GST: SLE scheduling system
 - APL: Secure web based
- **Procure, configure, integrate and test SLE front ends (Avtec PTPs) at:**
 - APL
 - CERES
- **Obtain AF approvals**
 - DAA
 - Tracking TACOs spacecraft
- **Tracking**
 - Perform check-out passes
 - Perform operational passes

DataLynx/APL Network Configuration

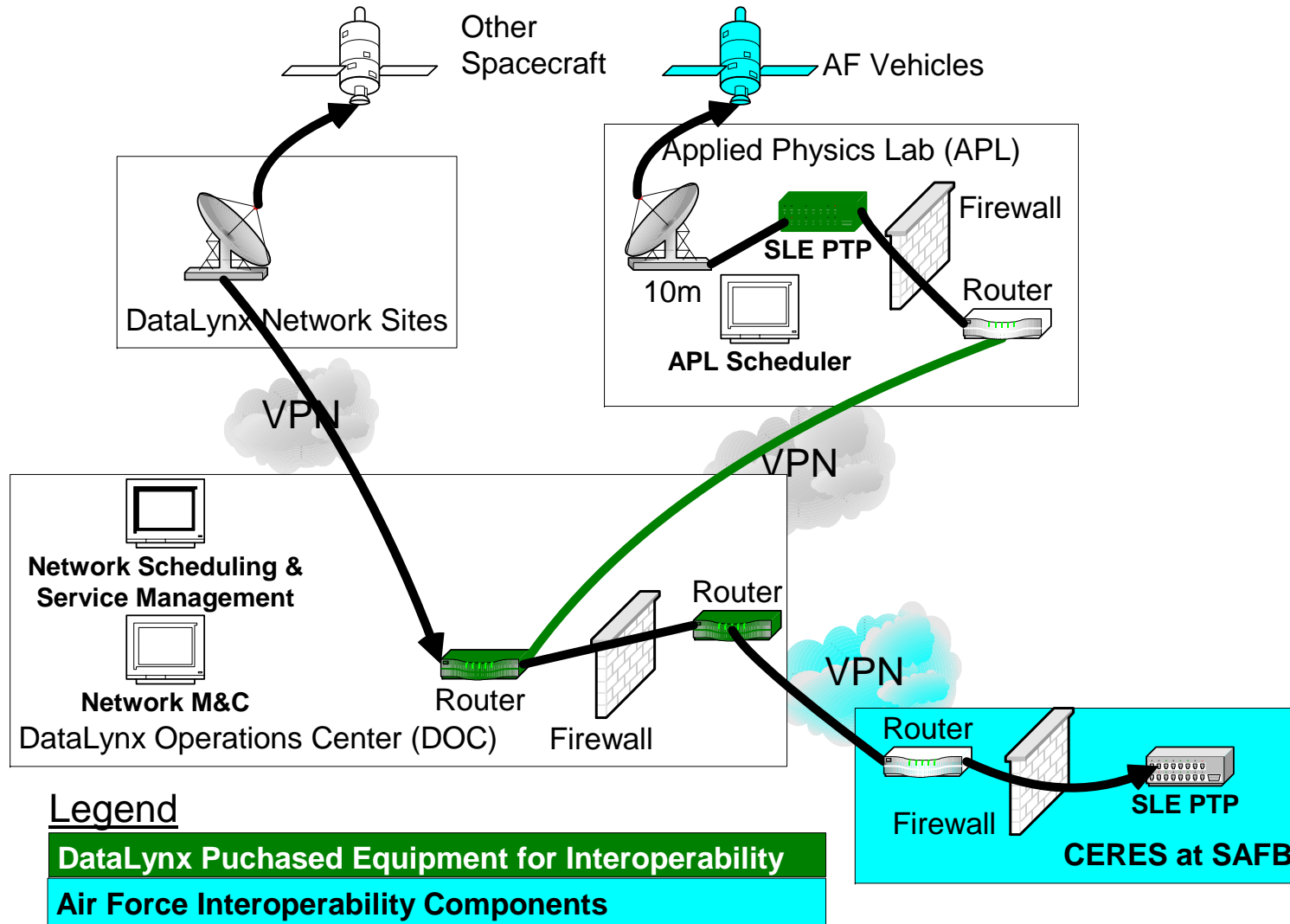

Data Transfer Interfaces and Edge Devices

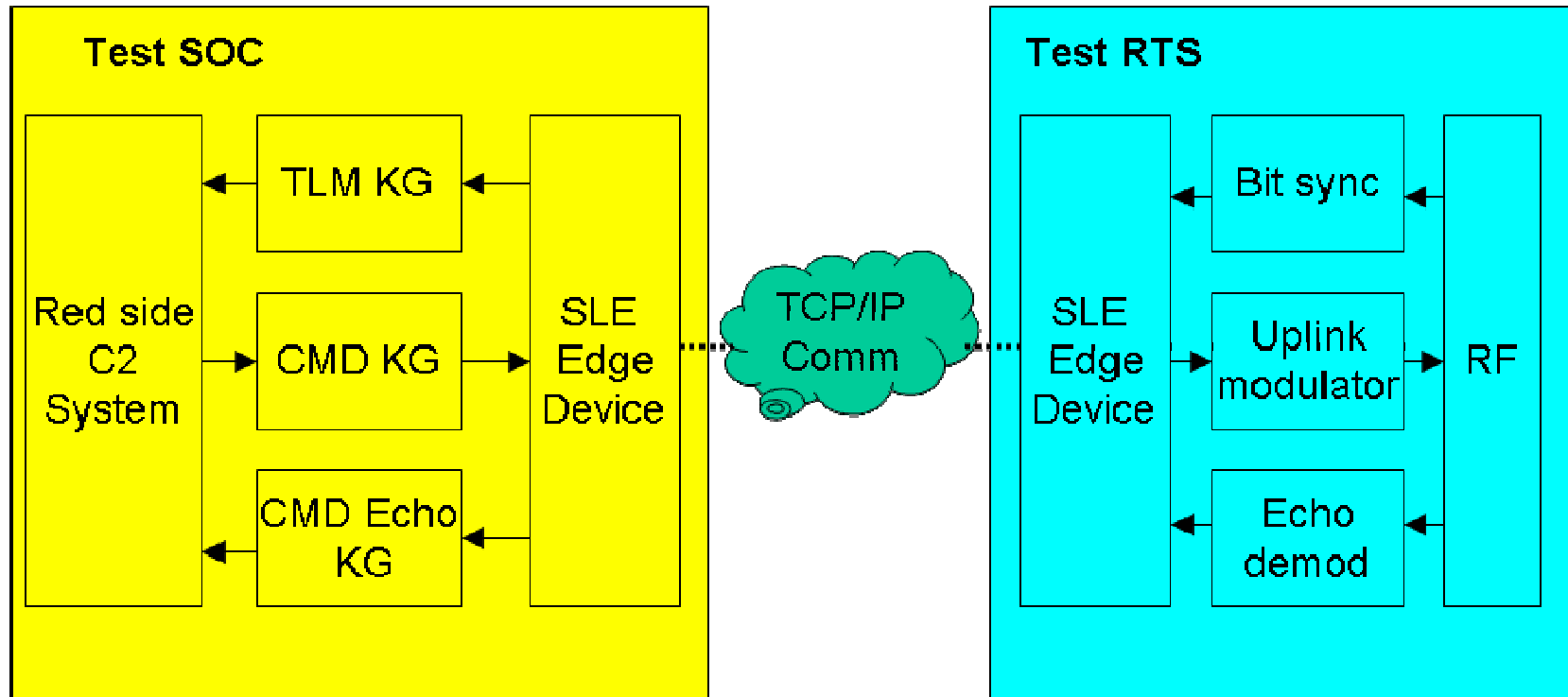

AF Performance Evaluation Results of DataLynx/APL

Performance Evaluation Criteria:

1. Time/data correlation and time-critical commanding
2. Responsiveness and effectiveness
3. The interface and concept of operations for scheduling
4. Security considerations and implications of connectivity

Results:

1. DataLynx/APL did achieve critical AFSCN time/data correlation and time-critical commanding
2. DataLynx/APL did provide acceptable levels responsiveness and effectiveness
3. The interface and concept of operations for DataLynx/APL scheduling was verified
4. The DataLynx/APL connectivity was not as secure as AFSCN sites, which are under military protection. However, DataLynx/APL does offer usable augmentation of the AFSCN for programs that use source-encrypted data.

APL Tracking Summary Results

- TSX-5 failed on orbit before Phase 3 testing could begin
- APL could not close the link on DSCS II due to degraded performance of the spacecraft, leaving only DSCS III for testing

Link delay (ms)	Command mode	Passes	Illegal command passes
50	streaming	56	48
650	streaming	34	22
50	discrete	59	48
650	discrete	50	48
Total		199	166

- Command Success of 100% was achieved 193 out of 199
 - 5 failures due to lockup of the SLE edge devices, rebooting did clear the problem
 - 1 failure, reason unknown

APL Tracking Results Continued

- Telemetry Performance
 - 6 passes out of 199 has significant drops
 - 2 failures attributed to SLE edge device lockups
 - 4 unknown failures
- Time critical commanding (illegal commanding) Performance was 162 out of 166
 - 3 failures due to edge devices and 1 marginal pass

Summary

- PTP products delivered and worked as specified
- Long lead times needed for government actions
- Security and connectivity approvals can be long pole
- Configuring DataLynx and APL for SLE AF satellite contact parameters was straightforward
- Results demonstrated DataLynx can meet technical requirements to support DoD spacecraft
- Commercial augmentation can provide cost-effective alternatives when there are temporary surges in requirements especially to support less sensitive assets

Acknowledgements

- **Satellite Control Network Contract (SCNC) Interoperability Team**
 - Lance Williams
 - Lonnie Mathias
- **Space and Missile Systems Center (SMC)/SNAI**
 - Captain Rob Thompson
- **The Aerospace Corporation**
 - Dr. Carl Sunshine
- **Global Science & Technology (GST)**
 - John Pietras
- **SMC Det 12**
 - Center for Research Support (CERES)
 - Aaron Huey
 - CERES Engineering, Development & Sustainment (EDS) contract
 - Space Test and Engineering Contract (STEC) operations
- **Avtec**
 - Brian Safigan
- **Johns Hopkins University/Applied Physics Laboratory (JHU/APL)**
 - Glen Baer