

# GENERAL DYNAMICS

## GSAW 2007 SW Architecture Workshop - Managing the Complexity of Your Large-Scale Software Architecture and Design

**Richard Anthony**  
[richard.anthony@gdc4s.com](mailto:richard.anthony@gdc4s.com)  
March 27, 2007

# Introduction

---

- Target Audience for This Presentation:
  - SW Architects at all levels on a project
  - Stakeholders for SW Architecture and Design
    - Government Customers, Prime Contractor, Managers, System Engineers, SW designers and implementers, Testers, ...
- Your Software Will Have an Architecture
  - Whether you document it or not
  - Whether you manage its definition or not
- SW Architect Defines the Vision for all the Architecture and Design that Occurs
  - This Includes Architectural Viewpoints and Views (IEEE 1471) in UML
- Views Described Here based on Wiley book on Large-Scale Software Architecture (reference at end)
- While Focus is Large-Scale, Approaches Described Here also Work Well for Smaller Systems and Embedded Systems

# Run-Time vs. Build-Time Architecture and Design

- Run-Time
  - SW Components
    - Run-time grouping of objects with well-defined interfaces
  - SW Processes
    - Look at Task Manager process tab or Unix ps command
  - SW Deployment
    - How does SW map to hardware processors, nodes, etc.
- Build Time
  - Subsystems
    - Collection of classes, maps directly to directory in build
  - Classes
    - Encapsulation of attributes and methods
- Keep Run-Time / Build-Time Distinction Clear in all SW Design Documents

# Run-Time / Build-Time View Examples

Run-Time

COMPONENT

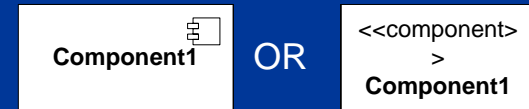

PROCESS

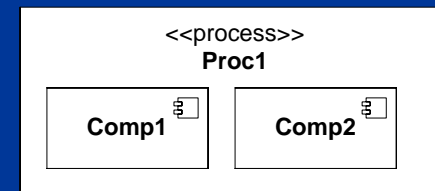

DEPLOYMENT

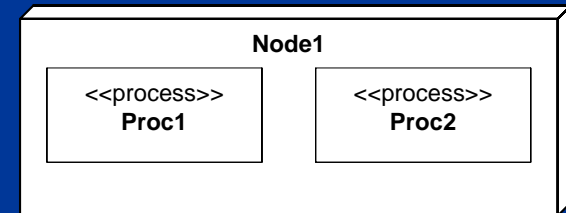

Build-Time

CLASS

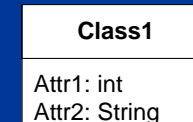

SUBSYSTEM

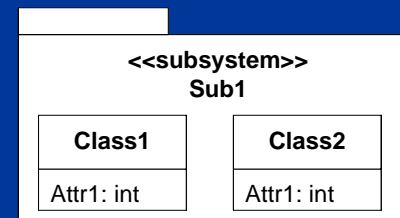

# Hierarchical Component (Run-Time) Architecture

Top-Level Component View

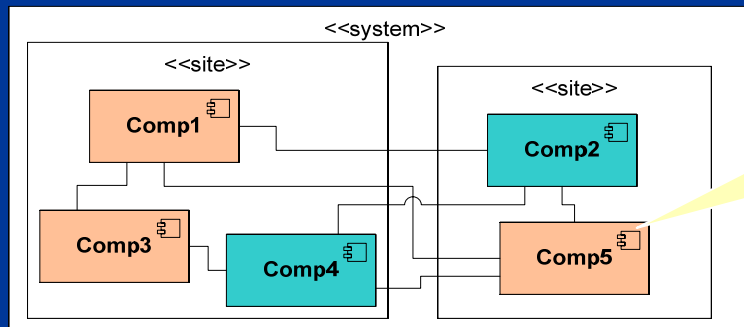

Colors indicate CSCI mapping of Components

Domain/Segment Level Comp Views

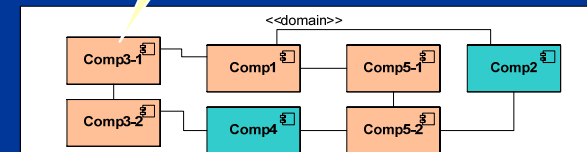
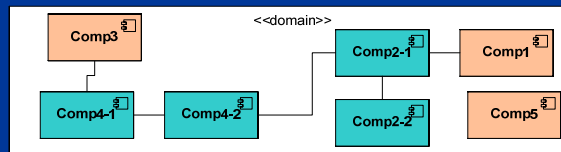

CSCI-Level Comp Views

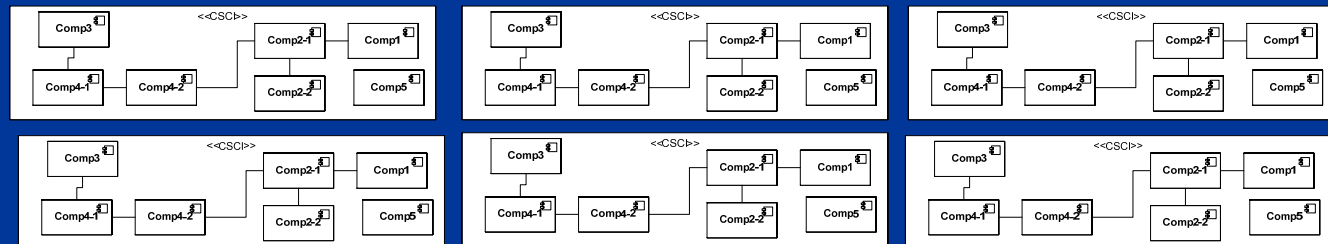

# Top-Level SW Architecture Document (TLSAD)

- TLSAD Document Contents
  - System Overview
  - Top-Level Component View
    - Component Descriptions
    - Interface Descriptions
  - Domain-Level Component Views
    - Component Descriptions
    - Interface Descriptions
  - Other Information
    - System-Wide Decisions / Constraints
    - Mapping of Interfaces to Documents
- Owned by SW Architect for the System Under Design
- Interface Definitions Best Managed in a Tool or DB

# Mapping (Reuse) of TLSAD Information

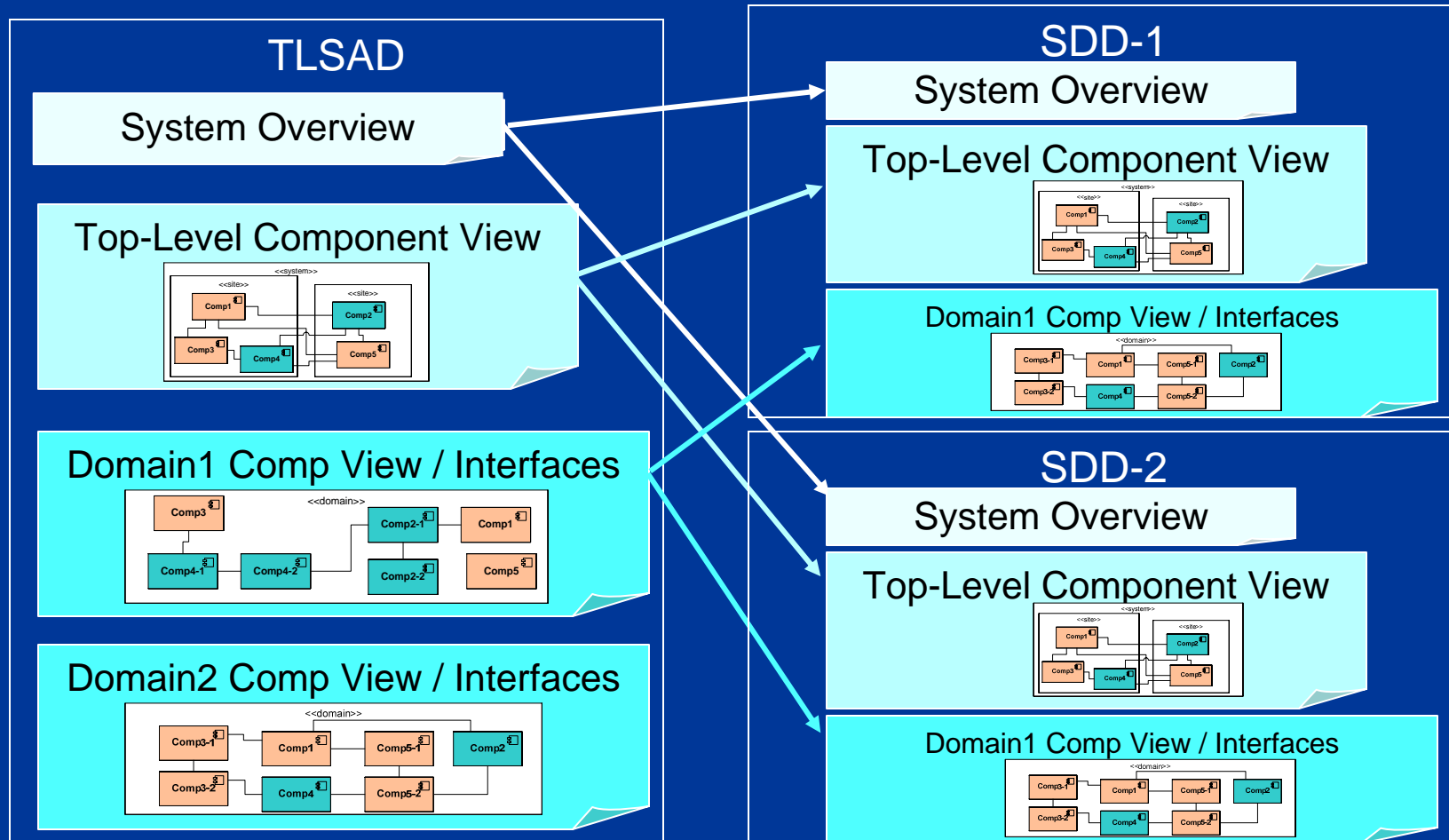

# Effectively Capturing SW Architecture and Design in the SDD

SDD-x (Content maps to MIL-STD-498 and DoD 2167A)

## 1. Overview

System Overview

Top-Level Component View

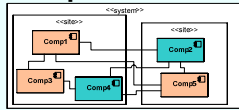

Domain1 Comp View / Interfaces

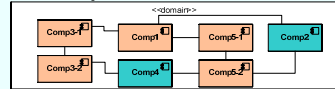

## 2. CSCI Architecture

Design Decisions

CSCI Comp View / Interfaces

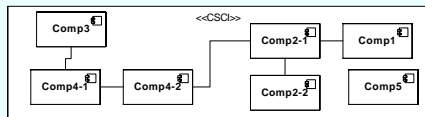

## 3. Hardware Utilization

Deployment View / Process Descriptions

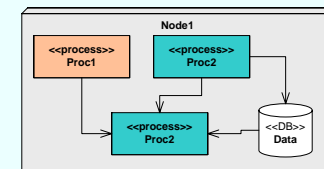

## 4. Detailed Design

Subsystem1 Views / Descriptions

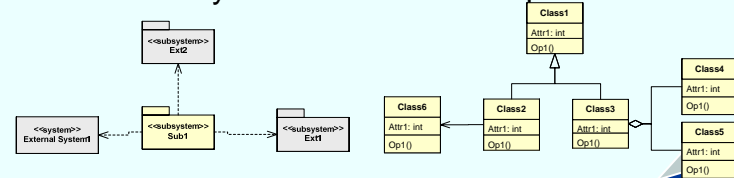

Subsystem2 Views / Descriptions

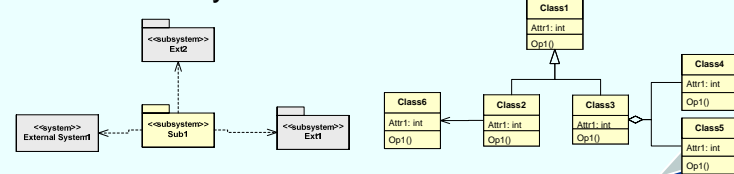

# Conclusions

---

- Management of SW Architecture Complexity is Critical to Success of Large-Scale SW Systems
- Keys to Success
  - Run-Time vs. Build-Time
  - Hierarchical Definition of SW Architecture
  - TLSAD Provides Centralized Management of Component Architecture and Interfaces
  - Consistent Approach to SW Architecture and Design Enhances Communication
    - Within the Project and with Customers

# References

---

- Large-Scale SW Architecture (Wiley) – Garland/Anthony
  - [largescalesoftwarearchitecture.com](http://largescalesoftwarearchitecture.com)
- Software Systems Architecture: Working With Stakeholders Using Viewpoints and Perspectives (Addison-Wesley) – Rozanski / Woods
- Pattern-Oriented Software Architecture, Volume 1 (Wiley) – Buschmann, et al.
- Patterns of Enterprise Application Architecture (Addison-Wesley) – Martin Fowler