

# Proposal For The Application of CCSDS Space Link Extension to NASA Human Space Flight Missions

March 2003

**Larry Muzny**

**Jeff Boxell**

Lockheed Martin Space Operations  
Consolidated Space Operations Contract

[Larry.Muzny@csconline.com](mailto:Larry.Muzny@csconline.com)

[Jeff.Boxell@csconline.com](mailto:Jeff.Boxell@csconline.com)

## Problem

- **Currently defined Space Link Extension (SLE) transfer services have not been explicitly developed to support Human Space Flight (HSF) missions**

## Objective

- **Present a common CCSDS SLE design which can support both standard CCSDS compliant missions and legacy HSF missions at the ground tracking stations**
  - There is a definite cost advantage to using common equipment vs using separate equipment for each type of transfer service

- **CCSDS Standard Reference model has provisions for 10 return (downlink) and 10 forward (Uplink) SLE transfer services**
  - Only SLE three transfer services have wide acceptance and have been selected for operational support
    - Return All Frames (RAF) - Released (blue book) April 2002
    - Return Channel Frames (RCF) - Review status (blue book release is expected soon)
    - Command Link Transmission Unit (CLTU) Forward - Released (blue book) April 2002
  - Two services have been written for review, but not selected for NASA missions
    - Forward Space Packet Service
    - Telecommand Frame Service
  - CCSDS “Forward” Advance Orbital System (AOS) services have not been developed
- **CCSDS SLE RAF and RCF transfer services are defined for missions which have CCSDS compliant space links**
  - Only supports CCSDS compliant telemetry frames with fixed 32 bit Attached Sync Marker (ASM) and Error Code Blocks per CCSDS Telemetry Channel Coding Standard
  - Supports CCSDS Version 1 Transfer Frames
  - Supports CCSDS Version 2 Transfer Frames (CCSDS Advance Orbital Systems AOS)

## Return Link Services

# Standard Model per RAF Released Recommendations

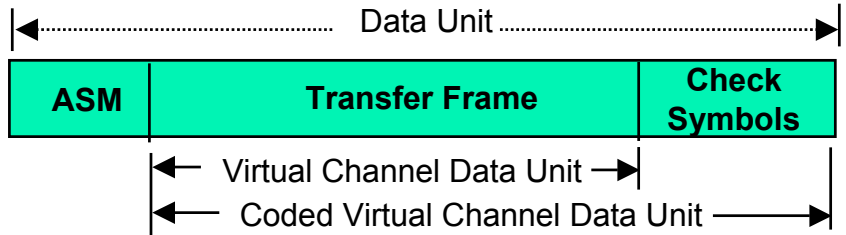
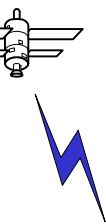

= SLE Transfer Service

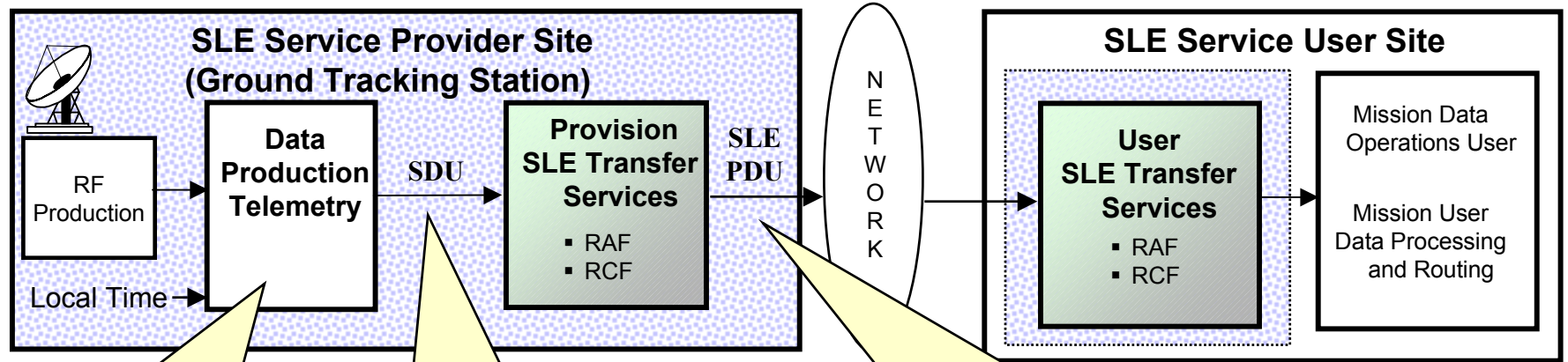

- Functions Includes:
- Bit Sync
  - Convolutional Decoding
  - Removes Pseudo randomization
  - Frame Sync
  - Error Processing
  - Data Annotation
  - Collection and Reporting
  - Data Storage

- SLE Data Unit includes:
- Data Unit
  - Data annotation
    - Earth Receipt Time
    - Antenna Identifier
    - Error Correction status (Good, Erred)
    - Data Quality Information

- SLE Protocol Data Unit includes:
- Data
    - Transfer frame or VCDU if frame quality is good
    - Full CVCDU if frame quality is Erred
  - Data annotation
    - Earth Receipt Time
    - Antenna Identifier
    - Error Correction status (Good, Erred)
    - Data Link Continuity (direct successor, or number of missing frames)
    - Optional annotation per mission

Note: Attached Symbol Marker (ASM) always removed



- **International Space Station (ISS) return link uses CCSDS Advance Orbital System (AOS) which is supported by CCSDS RAF and RCF transfer services**
  - The capability of SLE to support ISS Ku-Band data rates up to 150 Mb/s needs to be tested
- **Space Shuttle return link uses Time Division Multiplex (TDM) bit stream which is not CCSDS compliant**

## Key Requirement Comparison

CCSDS RAF/RCF Standards	Space Shuttle
<b>Requires CCSDS Compliant Frames</b> <ul style="list-style-type: none"><li>➤ Requires a fixed 32 bit Attached Sync Marker (ASM)</li><li>➤ Requires an Error Correction Code</li></ul>	<b>Not CCSDS compliant</b> <ul style="list-style-type: none"><li>▪ When encrypted, must be handled as an unframed bit stream since it has no sync marker and no framing available</li><li>▪ If not encrypted, could be handled as a TDM return link<ul style="list-style-type: none"><li>➤ Does not use a CCSDS compliant sync pattern</li><li>➤ Does not use a CCSDS compliant Error Correction Code</li></ul></li></ul>

- **The capability to support unframed bit stream using SLE RAF has been successfully demonstrated by Global Science and Technology (GST) Corporation**
  - GST built a Research and Development (R& D) system for the Air Force which successfully demonstrated the capability to block unframed bit stream for routing using SLE RAF transfer service
    - Provided data production to time tag and block unframed downlink telemetry into SLE SDUs for routing via SLE RAF transfer service
    - Provided capability to re-serialize the unframed telemetry at the user facility along with a IRIG time signal

The GST system is an R&D system which was specifically designed to test unframed bit stream routing. The GST system does not include data production capabilities to support standard CCSDS compliant spacecrafts.

- **The goal is to have a single commercial off the shelf (COTS) solution which can support both standard CCSDS compliant and unframed bit stream space links**
  - The Lockheed Martin/CSOC SLE prototype uses a standard COTS Avtec Systems programmable telemetry processor (PTP) with CCSDS SLE RAF, RCF, and CLTU services
    - Avtec was selected because they have delivered SLE CLTU service to the JPL Deep Space Network (DSN)
    - Included features to support TDM and unframed telemetry space links
  - CCSDS Panel 3 Status
    - Panel 3 has agreed to add a new “undetermined” delivered-frame-quality status which could be used to handle the unframed data, but this change was not incorporated into the recent CCSDS RAF Blue book release
    - Full scope of the Panel 3 agreements were not available at the time we were developing requirements for the Avtec implementation

# With additions to support TDM and Bit Steam (Avtec Systems Implementation)

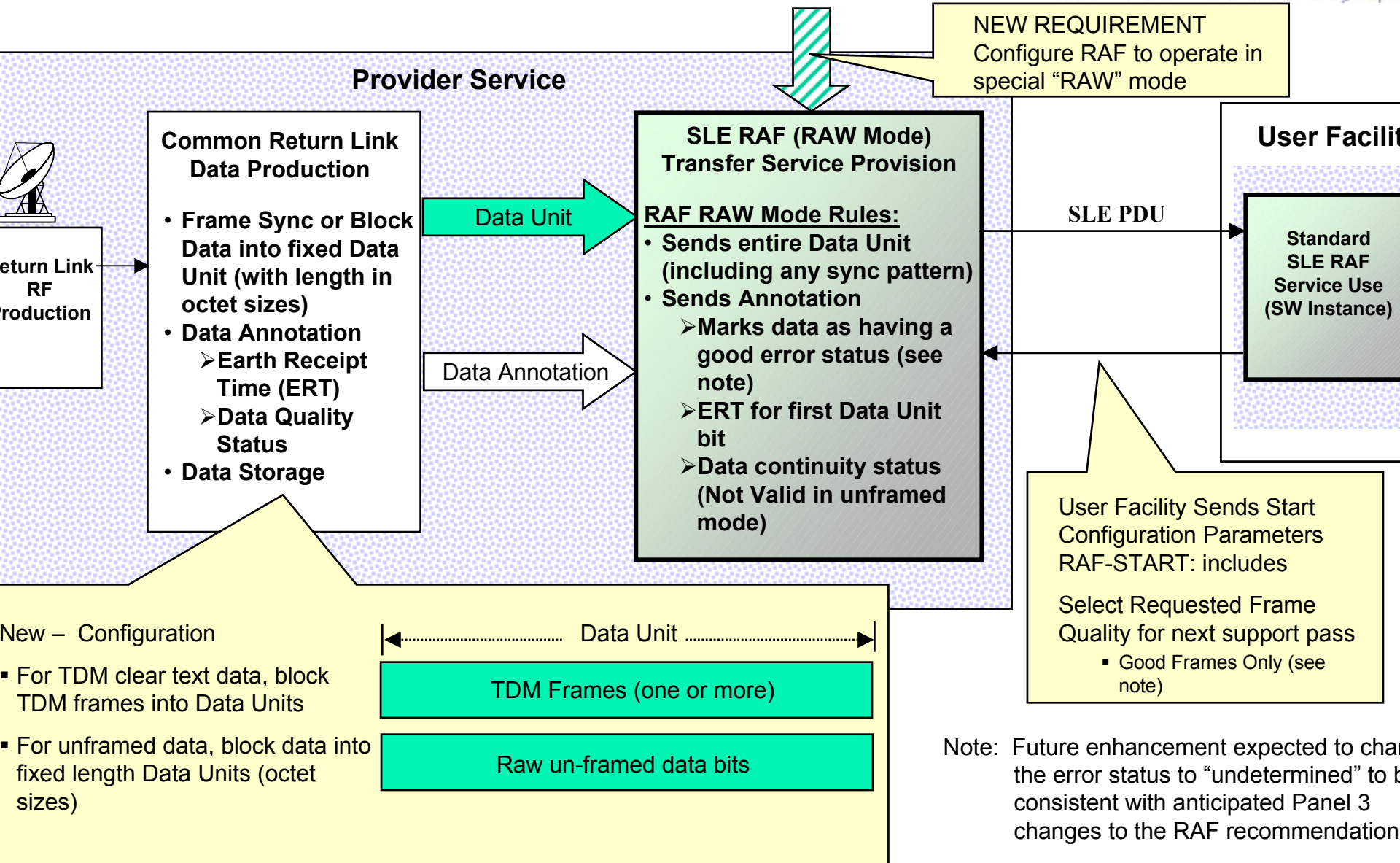

- **Service user sites supporting missions using TDM frames or unframed bit stream must have the following capability**
  - Configure SLE provider service for the “RAW” mode operation
    - Through site scheduling or SLE management
  - For unframed data, need a function to re-serialize the SLE Protocol Data Units (PDUs) into a continuous serial stream for processing

# SLE Supporting Shuttle Return Link

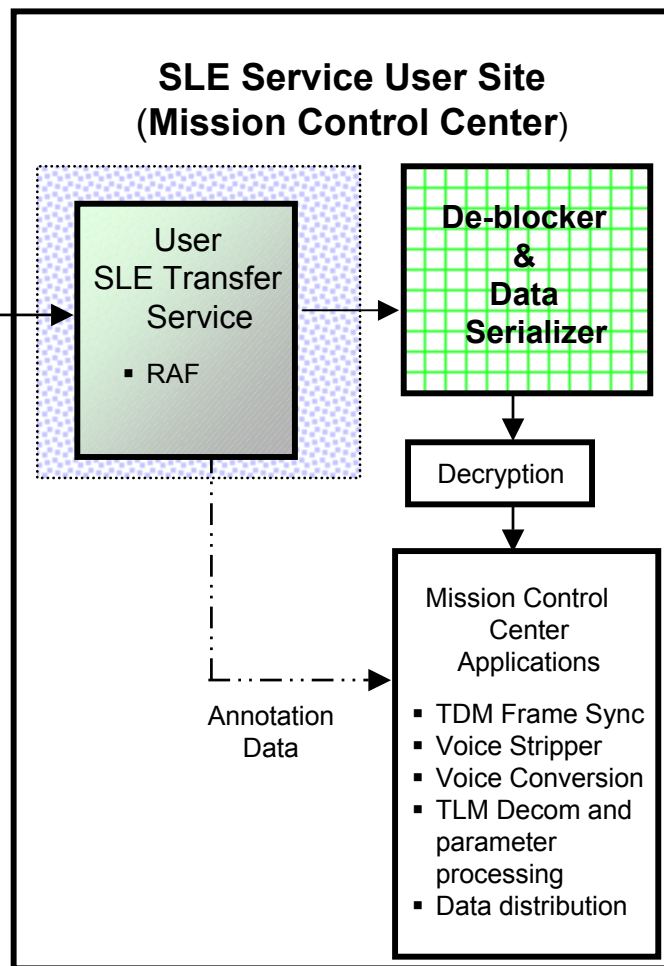
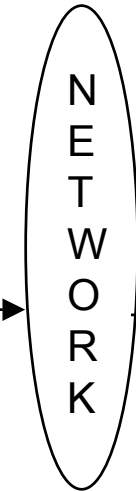
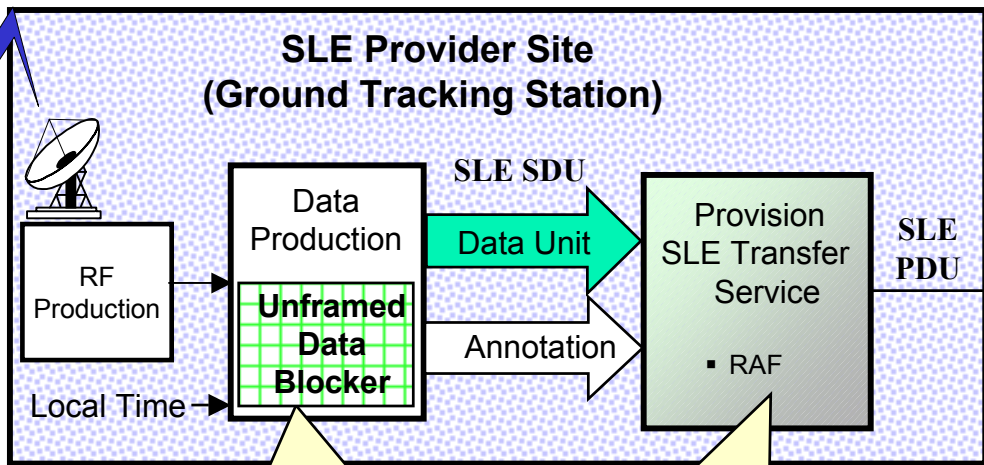
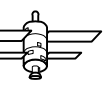

- Functions Includes:
- Blocks Unframed data into RAF Data Unit
  - Data Annotation Collection and Reporting
  - Data Storage

RAW Mode Operation

= New Functional Required  
 = SLE Transfer Services

# SLE Supporting Onboard TDM Return Link

## If Shuttle Downlink TDM framing is available

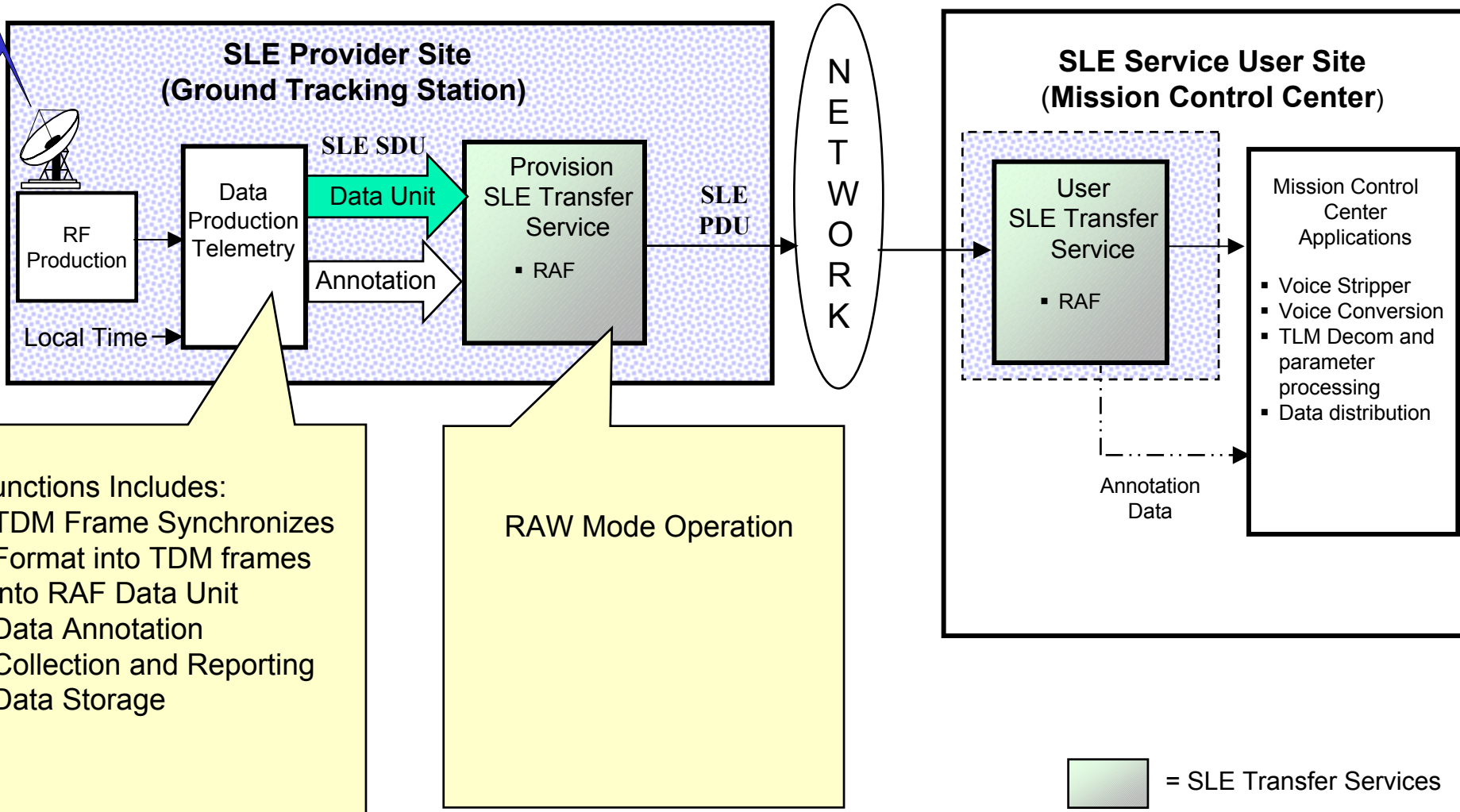

## Forward Link Services

# Standard Model per CLTU Released Recommendations

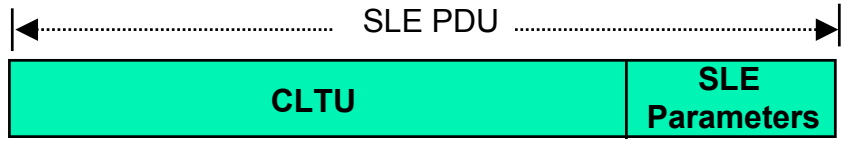
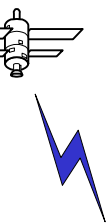

= SLE Transfer Service

**Note: SLE Transfer Service does not interpret, interrogate, or modify the content of the CLTU**

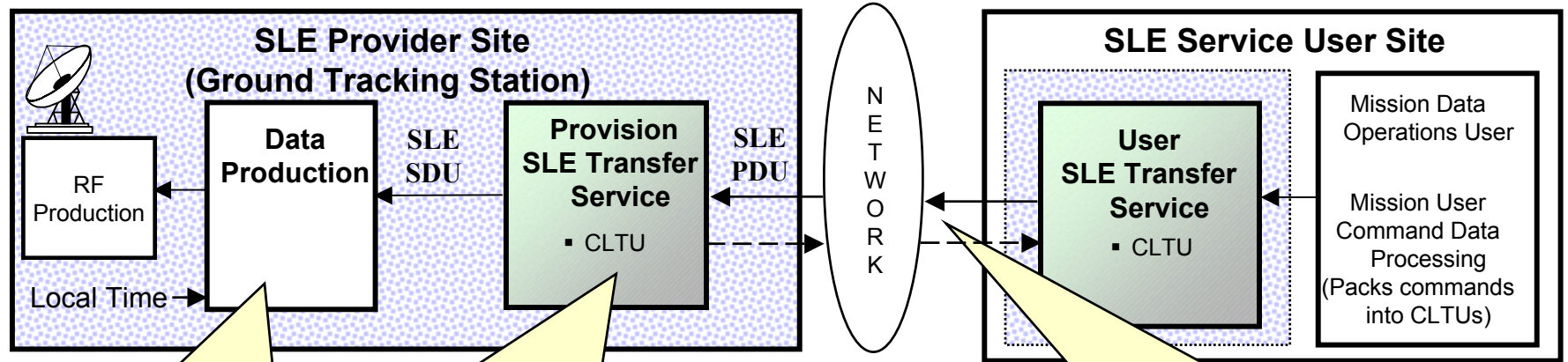

**Function:**  
Generates acquisition sequence and idle sequence on the physical channel in accordance with mission unique configuration parameters

**CLTU Transfer Service:**

- Buffers CLTUs to maintain a steady stream of CLTUs despite variable latency of the ground network
- Transmits the CLTU unmodified
- Provide CLTU transfer status to the SLE service user site

**CLTU-TRANSFER-DATA Operation:**

- SLE User service sends a CLTU Protocol Data Unit
  - CLTU data
  - CLTU identifier, radiation times, delay times, etc.
- SLE Provision service returns response with CLTU-BUFFER-AVAILABLE status, CLTU identifier, etc.

- **Space Shuttle forward link is an unframed bit stream generated by the Mission Control Center at Johnson Space Center (JSC)**
- **Space Station forward link is a CCSDS AOS continuous bit stream of Channel Access Data Units (CADUs)**
  - CCSDS AOS processing is expected to remain in MCC at JSC

***Note:***

**This presentation only investigates SLE CLTU service. Other options exist for CCSDS AOS forward service, but will require development and approval of a new CCSDS AOS SLE transfer service by the CCSDS Panel 3 committee**

- **SLE CLTU transfer service is expected to support the requirements for both Space Shuttle TDM forward link and Space Station CCSDS AOS forward link**
- **User Site requires new functions for handling bit stream data**
  - To block unframed uplink into SLE CLTUs
  - To manage data production buffering necessary to maintain a continuous serial uplink data stream which accounts for ground network delays and variations
- **Standard COTS Forward Service Data Production equipment is expected to support the requirement to re-serialize the CLTUs back-to-back without adding fill data**

***Further testing is needed to verify this capability and make the tradeoff between network conditions (delays and variation) and maximum acceptable latencies.***

# SLE Supporting Shuttle or ISS Forward Link

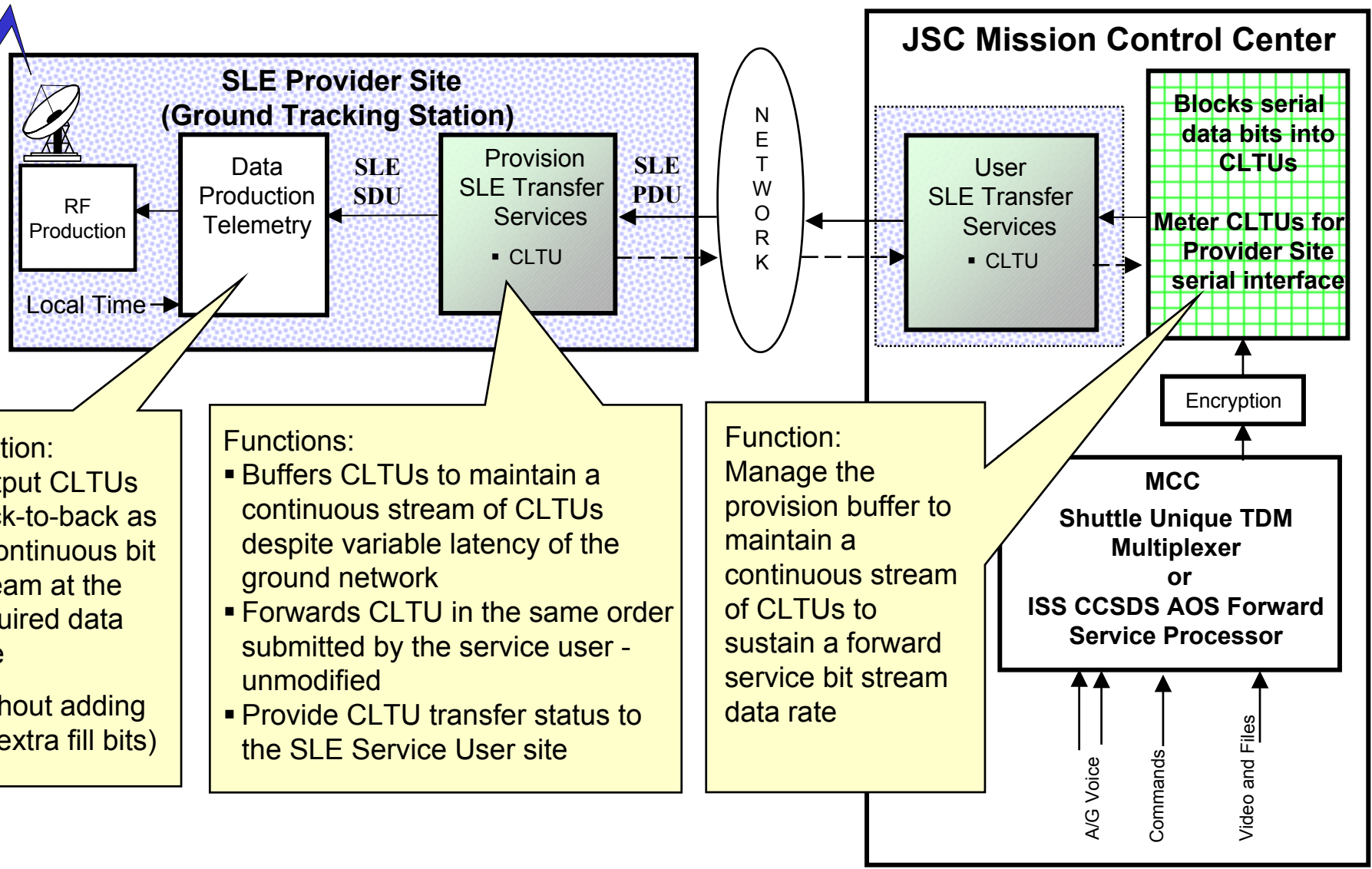

Function:

- Output CLTUs back-to-back as a continuous bit stream at the required data rate

(without adding any extra fill bits)

Functions:

- Buffers CLTUs to maintain a continuous stream of CLTUs despite variable latency of the ground network
- Forwards CLTU in the same order submitted by the service user - unmodified
- Provide CLTU transfer status to the SLE Service User site

Function:

Manage the provision buffer to maintain a continuous stream of CLTUs to sustain a forward service bit stream data rate

- **The goal of common equipment to support standard CCSDS missions and legacy missions is believed to be achievable**
  - CCSDS Panel 3 is expected to make changes to the RAF specification to support the equivalent of the “RAW” mode presented in this presentation
- **Further testing is required**
  - Verify the capability of SLE CLTU transfer service to support unframed bit stream for HSF missions
    - Verify command data latencies can be met with the varying network conditions
  - Verify that SLE can support the HSF high data rate requirements